

# CLIMA DOOR

## Aluminium Heritage French Doors Fitting Instructions

**Please read the complete set of instructions before starting installation to familiarise yourself with the stages of construction.**

These instructions cover the fitting of the above doors complete with outer frame & cill (& ventilator if ordered as a special item add-on) into a new or existing brickwork opening.

The size of the opening should be:

**Width:** The external width of the frame + 10mm fitting tolerance.

**Height:** The external height of the frame + 25mm for the cill + 10mm fitting tolerance (+ 42mm for the ventilator if ordered as a special item add-on).

### Important Information

1. Before proceeding, you will need to check that your new door is the correct size and handing to fit the intended aperture. **Do not remove your old frame until you have confirmed all the points below.**
2. Carefully open the packs supplied and check the contents against the included list.
3. Do not destroy any of the packaging until you have the fitting complete. In all cases keep any barcodes attached to the door or instructions safe as these will be needed in the event of aftercare contact.
4. For future use and adjustment requirements please retain all assembly instructions
5. Structural openings should be free of dust and debris and checked to make sure D.P.C is undamaged and in position.
6. Levelling and plumbing; it is important that you check the level and plumb when installing the frame.

### Delivery Check List

- Unglazed door frame and sash(es)
- The correct number of glass panes for the door supplied.
- Overhead Ventilator Bar to cover full width of door and sidelites (If ordered as a special item)
- External cill and end caps to cover full width of door and sidelites (where included)
- Trickle vents, internal and external parts and fixing screws (if ventilator bar was ordered as a special item add-on).
- Cylinder and keys
- Cill fixing screws
- Handle set with spindle and fixing screws.
- Gasket bags – 1 bag of each type per sash and sidelite

### Equipment Required (not supplied)

- Electric/Battery drill
- Various drill bits
- Selection of screwdrivers
- Selection of Allen Keys
- Tape measure
- Rubber / soft hammer
- Spirit level
- Suitable frame to brickwork fixings
- A selection of wedges/packers
- Silicone sealant
- Frame trims (if required)
- 

### Notes for guidance - Please read.

- Viewed from the outside, the hinges determine what hand door you require.
- These doors are heavy. Always use good lifting practices, be especially careful when the door is in the opening before securing.
- Fitting these doors plumb level and square is of paramount importance.
- Maintain even gaps all around the frame.
- If an external cill is supplied, it is important that it is fitted due to the frame drainage.

**The doors may not operate correctly if you do not:**

- Fit the door frame level.
- Fit the door frame plumb in all planes.
- Fit the door frame square.
- Keep even gaps around the frame.
- Tighten fixing screws against packers.

### Step 1 – Preparation

Before starting the installation of your new door, and prior to removing the old door and frame, check all dimensions including the cill and vent (if ordered as a special item add-on) to ensure they fit your brickwork opening correctly. Cills and overhead vents may need to be cut to size to fit the brickwork as needed.

It is recommended that old doors and windows should not be removed until all the new materials are on site and have been checked and confirmed ok and free from any damages.

**Note - Any damages must be reported BEFORE commencing fitting. Damages reported after fitting will not be covered under our guarantee.**

The door frame must be fitted under a lintel which extends at least 150mm onto brickwork at both sides of the opening. This must be checked before the opening is prepared and any old frames removed. If an existing lintel is not sufficiently wide, a new lintel will need to be installed. The brickwork opening dimensions must be slightly larger than the external frame dimensions to allow for packing and square fixing of the frame. There needs to be a clearance of approximately 5mm between the new frame and the brickwork. (Jambs and head only).

A clean and square opening must be prepared. Any wall cavity, which has been opened, must be closed, incorporating a damp-proof course. Check that a damp-proof course is in place at the cill level. If not, one will need to be installed.

### Step 2 - Unpacking

Place your door on a ground sheet to protect from damage, remove all packaging and check that you have all the hardware, glass, and all items from the checklist above.

### Step 3 – Fitting the cill.

If required, cut the cill to the length of the brickwork opening. Offer the cill into the opening, check the cill is level across its overall length. **(Maximum deviation is 2mm)**. Drill a suitable hole for the cill fixing screws through the bottom of the door frame through to the cill, being careful only to pierce the outer skin of the cill. These holes should be approx. 150mm from either end with no more than 500mm between fixings. Run a bead of silicone inside the rear up-stand (the lip at the back of the cill) (fig 3.0) and fit the frame to the

cill by screwing from the frame down through the cill. Using suitable cill fixing screws (not provided), being careful not to over tighten. Ensure the cill is not distorted when fixing down. Apply silicone sealant to the cill end caps and push firmly into position. Wipe away any excess silicone and temporarily tape in place until sealant has cured. Once fitted into the brickwork, ensure a bead of silicone runs along the edge against the wall to stop any water runoff from returning around the cill.



### Step 4 – Fitting the Overhead Vent (If ordered as a special item add-on)

The trickle vents are stored in a cardboard tube within the packaging. Clip the internal and external trickle vent parts to the slots. Position the vented head onto the outer frame as shown, if you need to cut the vent down, cut an equal amount from both sides to keep the vent centralised. Apply a bead of silicone along the front and rear face where the vent meets the frame to seal it.

To secure the vent to the frame drill suitable holes through the frame head and into the underside of the ventilator bar approximately 50mm from each end then a further hole every 300mm (approx.) along the length. Secure the vent using supplied screws from the frame side taking care not to over tighten.

**Fig 5.0**

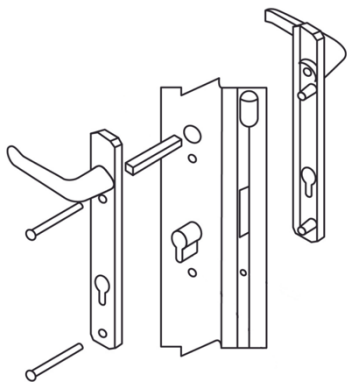

**Step 5 – Fitting the handle.**

Fix the master door handle & lock cylinder to the door. Ensure the handle fixing bolts are to the inside of the property.

**Step 6 – Fitting the Door Frame**

**6.1 Checking the fit of the frame.**

With the doors in the closed position in the frame, offer the frame into the prepared opening, and make the following 4 frame alignment checks.

1. Check that the cill is level.
2. Check the frame is vertical from side to side and from back to front. **Fig 6.1a**
3. Check that the frame diagonal dimensions are the same to ensure the frame is set square. **Fig 6.1b**
4. Make sure the frame is square and not bowed in any direction by measuring the width at the top, middle and bottom. **Fig 6.1b**

**Fig 6.1a**

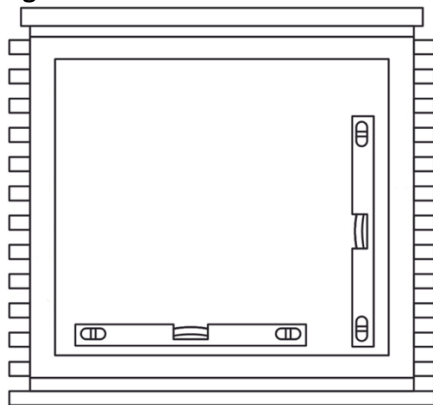

**Fig 6.1b**

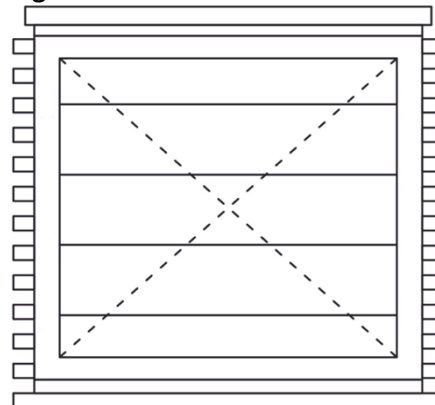

Measure diagonals & check uprights front and side – **NOTE – Doors not shown but need to be locked into place.**

Use wooden or plastic wedges (not supplied) to hold the frame in the opening, positioning the wedges directly above the frame jambs and close to the vertical ends of the jambs to avoid bending the frame and trapping the doors. Slip packings into the gap between the frame and the wall ready to take the permanent fixings @ minimum of 150mm from the top and bottom corners and equally spaced. Do not bend the frame in the process.

**Note: Most alignment and locking problems are because the frame is not installed correctly. Please take time and care to ensure that the frame is installed plumb, level and square.**

**Fig 4.0**

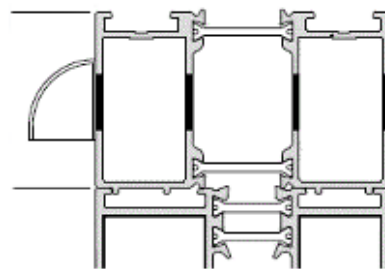

Trickle vent extrusion sits on top of frame with the opening vent inside and the fixed vent

Top of Frame

**Fig 6.2**

## 6.2 Preparing the fixings.

Ensuring the frame remains in a fixed position, open the door sashes. Support the weight of the doors to prevent them from disturbing the position of the frame. Drill a minimum of five holes into the outer frame verticals, a maximum of 150mm from the top and the bottom corners then equally space the holes. **(Fig 6.2)** The diameter of the holes you are drilling will depend on the type and size of fixing you are using to secure the frame in the opening. Ensure that the holes align with brickwork and not a mortar line.

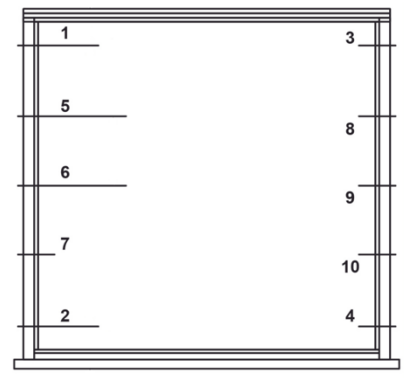

**Re check the frame alignment points 1 to 4, (as in section 6.1) to ensure the frame has not moved.**

Carefully drill a hole through the pre drilled hole in the frame at point 1, into the brickwork using a masonry bit. The diameter of the hole you are drilling will depend on the type and size of fixing you are using to secure the frame in the opening.

**6.3 Securing the frame in the opening** Secure the frame to the brick using your chosen size of frame fixer (not supplied). When tightening the screw use wooden / plastic packings to prevent the frame from distorting.

**Fully check that the frame has not moved by repeating the frame alignment checks 1 to 4, (as in section 6.1).**

Repeat this process for fixing the frame at the remaining points, thoroughly checking the alignment after making each frame fixing.

Another option would be to use fixing straps. Follow the manufacturer's instructions for using these.

**As earlier stated, most alignment and locking problems are because the frame is not installed correctly. Please take time & care to ensure the frame is installed plumb, level and square and the fitting sequence is followed.**

**Please ensure you do not overtighten the fixings as this can distort the aluminium profiles.**

When fixing down to the cill, ensure that screws are sealed with silicone to prevent water ingress into the profile.

The fixings in the head and cill should fit as flush as possible but it is important that these are not over tightened.

At this stage, the doors should be checked for correct operation.

**Check that the doors operate correctly before the glazing begins and check that the doors open, close and lock correctly.**

## 7. - Glazing

**7.1** - Close and lock all the doors.

**7.2** - Decide which door sash to glaze first, carefully remove the beads noting the position of each bead (top, left, right and bottom).

**7.3** – Fit the E-Gasket to the frame side of the sash in pieces, not in a continuous lengths. Leave the gaskets slightly over sized to avoid shrinking. Continue for the full sash. **Fig 7.3**

**7.4** – Add the glass packers as per the “toe and heeling” diagram in fig 7.4

**Note: It is essential that the doors have the glass installed with the glazing packers fitted in the correct positions as shown in the diagram “TOE & HEELING” below.**

**Failure to fit the packers tightly in the correct place will prevent the doors from operating correctly.**

**Fig 7.3**

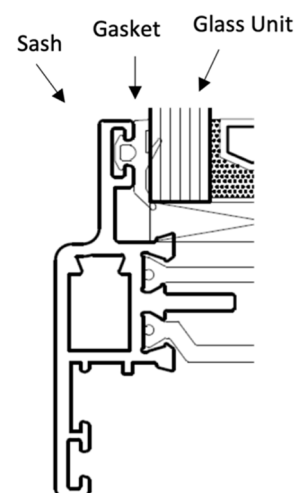
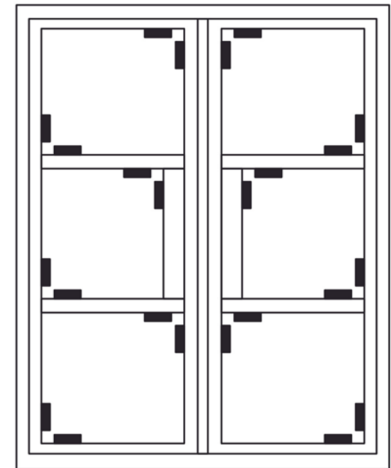

Fig 7.4



7.5 - Taking great care, one unit at a time, fit the glass and pack appropriately. When the glass is fully packed-out re-bead, placing the beads in their original locations in the order of top, bottom then sides.

**NOTE: Toughened Glass is extremely strong on its front faces once installed but very sensitive on its edges to sharp objects (small stones etc). Do not place direct glass edges onto concrete or paved areas etc use timber batons or similar if required as a support if you need to put it down.**

7.6 - Once complete, fit the wedge gasket into place in between the beads and glass. This needs to be done in pieces, not in a continuous length. Leave the gaskets slightly over sized to avoid shrinking. Continue for the full sash. **(Fig 7.6)** If fitting Laminated glass, you will need to tear away the extra fin to allow to fit correctly, otherwise this should remain in place as per Fig 7.6

Fig 7.6

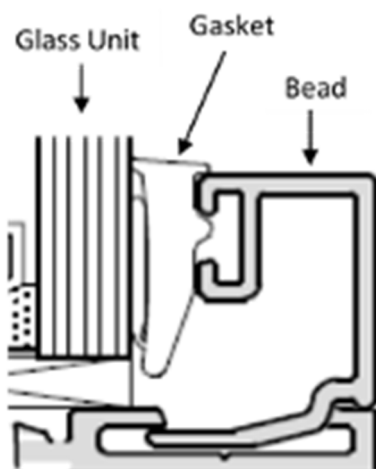

**TIP:** The wedge gasket will be tight to insert so it is beneficial to use some 'washing-up liquid' as a lubricant. It can also help if you wedge glazing packers between the bead and the glass. This helps compress the seal on the door behind the glass giving you more room to get the wedge gasket in. The use of a gasket glazing wheel may also help.

#### Step 8 – Check Door Operation

Once the door is fixed into place and the sashes glazed correctly, check the operation of the door to make sure it closes and locks correctly. It is possible that the hardware may need to be adjusted slightly. The doors can be lifted and lowered by slightly loosening the screws in the hinges (frame side). This should be the last option as normally ill-fitting doors are due to the frame not being fit square, or toe and healing not performed correctly.

#### Step 9 – Finishing

Once you are confident that the door is fitted correctly, fill any gaps between the masonry and the frame. If the gaps are too wide, a proprietary expanding P.U. filler or foam may be used, prior to finishing with a silicone sealant. Take care not to distort the frame by using too much foam filler and that the filler does not stain the doors. The gap between the frame and the brickwork can be covered using a trim if required.

The door will need to be sealed with silicone sealant and trims (if needed).

**Do not seal the gap between the top of the cill and the underside of the outer frame as this will prevent drainage.**

**Maintenance Guidelines. - These guidelines must be adhered to, or you will invalidate your guarantee.**

a) Products should be washed down periodically with a non-abrasive cleaner and warm water.

b) To maintain the mechanism and hinges, ensure they are always kept clear of obstruction like builders' rubble, plaster residue and other objects.

All Moving parts are to be periodically lubricated using a light, acid free lubricant to ensure continual ease of operation.